

Stückliste			
Pos.	Stück	Bezeichnung	Benennung
1	1	Gehäuse	
2	1	Grundplatte	
3	1	Kamin	
4	1	Kessel	
5	1	Kesselspitze	
6	4	Zugrad	
7	4	ISO 10642 - M5x16	Innensechskantschraube mit Senkkopf
8	2	ISO 4762 - M6x12	Innensechskantschraube
9	1	ISO 4762 - M6x10	Innensechskantschraube

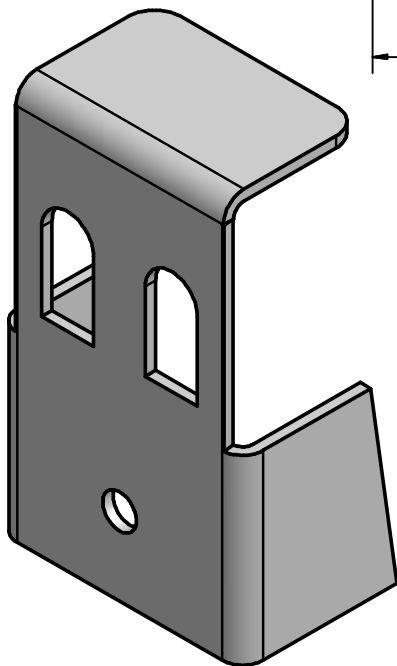
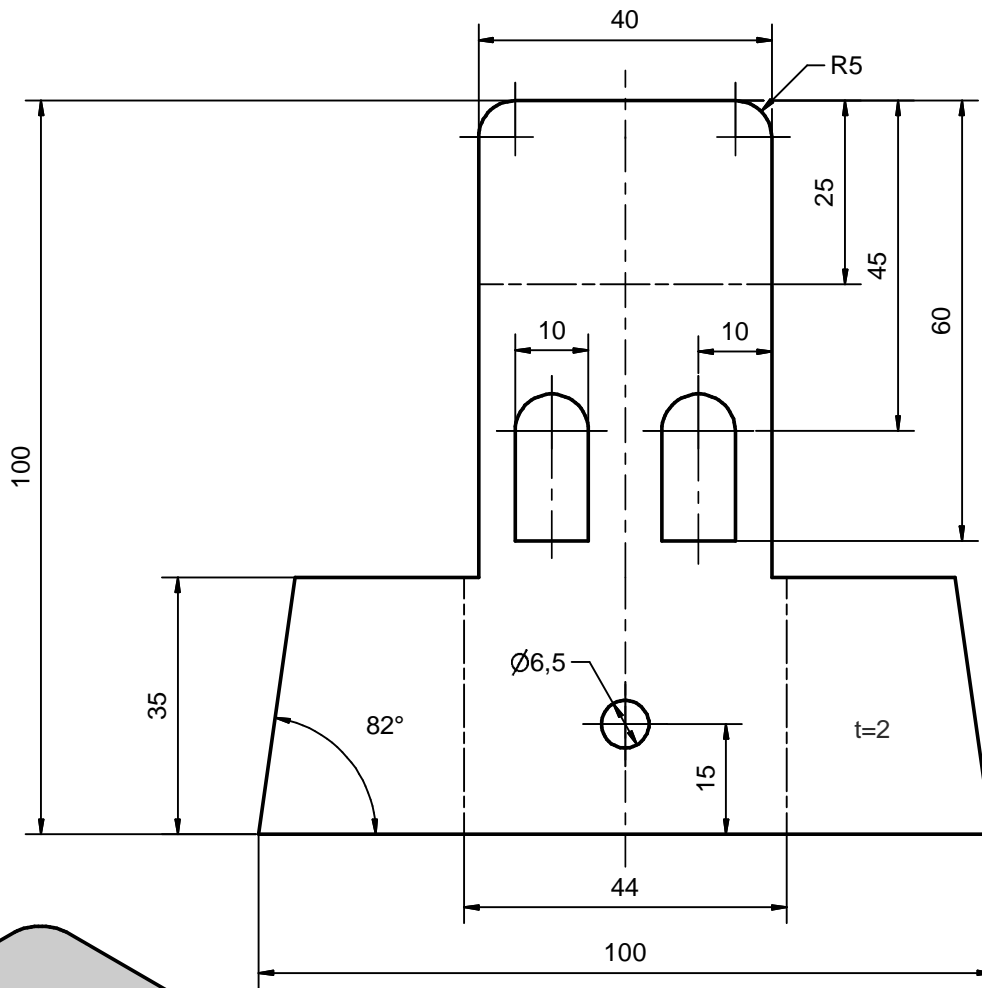

Rz25

		Zul.Abw.		Oberfläche		Maßstab:		Pos. Nr.: 3	
		DIN ISO 2768- m		DIN ISO 1302		Werkstoff: S235Jr			
						Rohteil: 100x2x95			
			Datum	Name		<h1>Gehäuseteil</h1>			
		Bearb.	22.03.2007	B.Kumpf					
		Gepr.							
		Norm							
				Gewerbeschule Lörrach		Lokomotive			2
									A4
Status	Änderungen	Datum	Name	B.Kumpf GWS-Lörrach 07621/429-311 B.Kumpf@gws-loerrach.de					

Pos.1

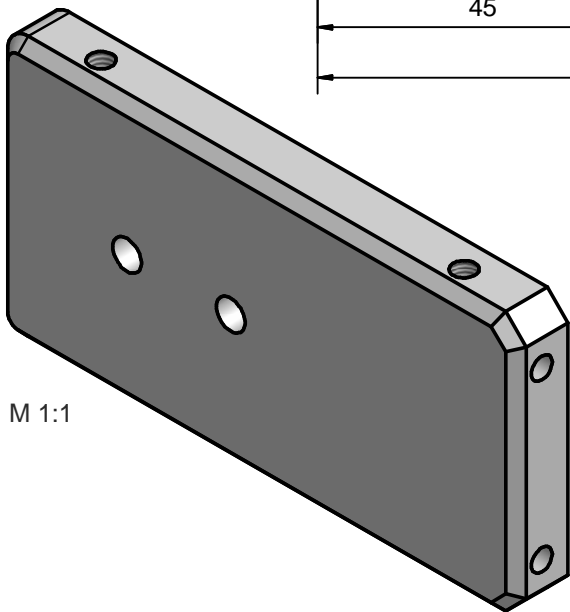
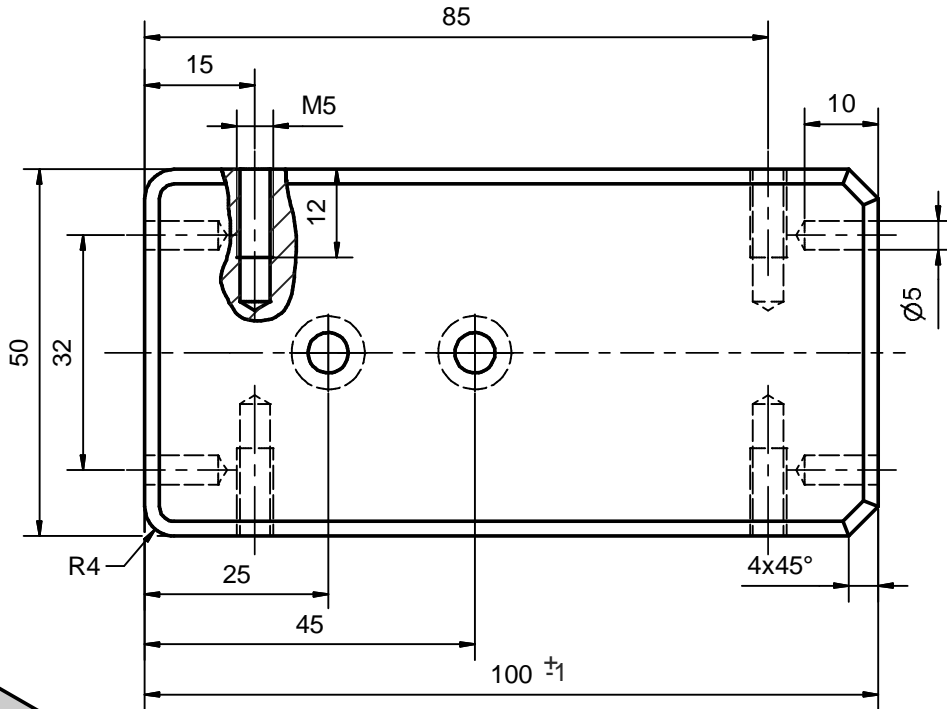
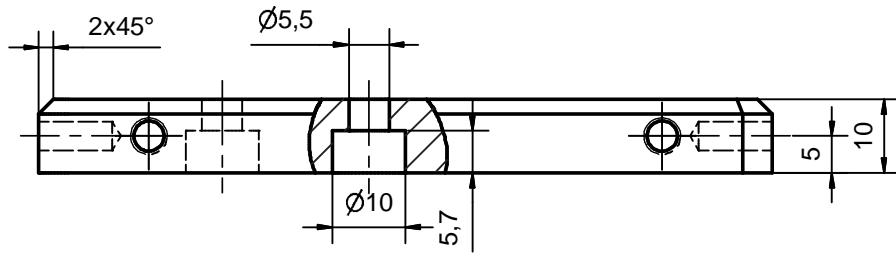

M 1:1

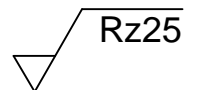

				Zul.Abw.	Oberfläche	Maßstab:	Pos. Nr.: 1
				DIN ISO 2768- m	DIN ISO 1302	Werkstoff: S235JR+C	
						Rohteil: 50x10x102 lg	
				Datum	Name	<h1>Grundplatte</h1>	
				Bearb. 23.03.2007	B.Kumpf		
				Gepr.			
				Norm			
				Gewerbeschule Lörrach		Lokomotive	3
							A4
Status	Änderungen	Datum	Name	B.Kumpf GWS-Lörrach 07621/429 -311 B.Kumpf@gws-loerrach.de			

M 2:1

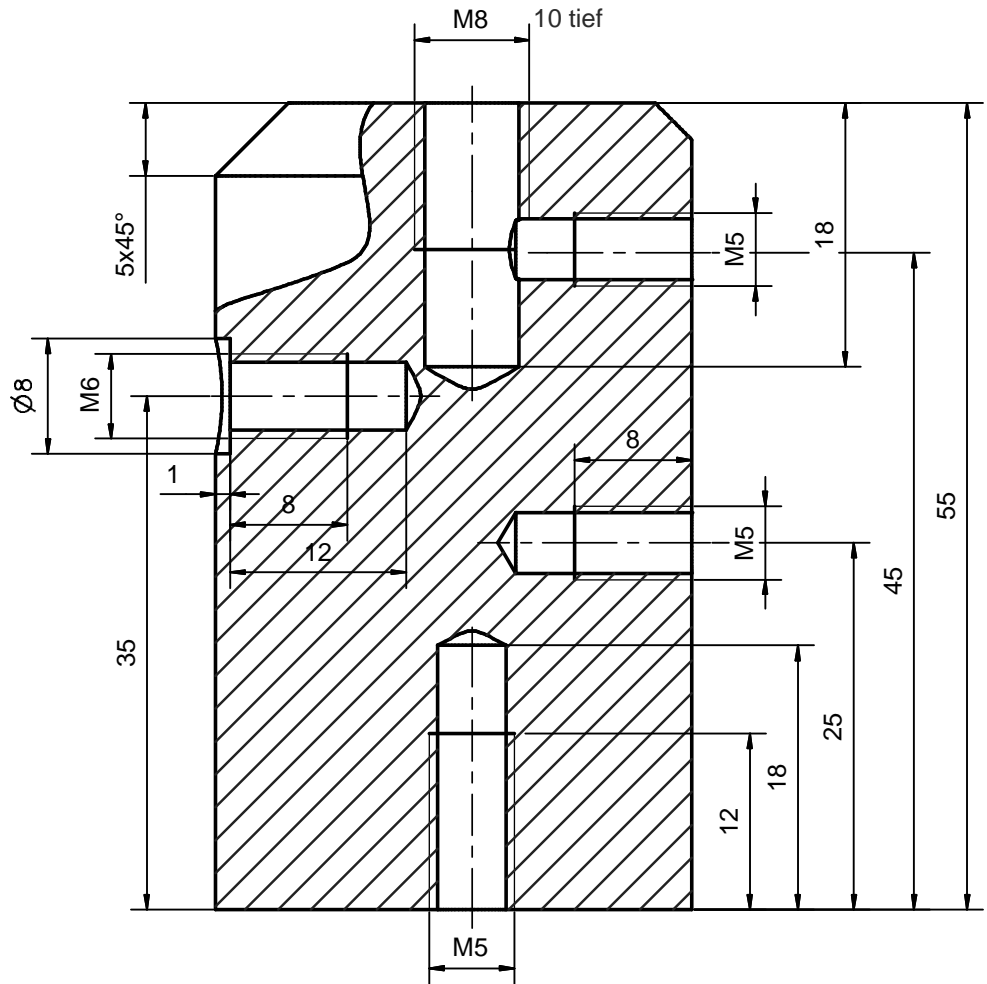

Pos.3 M:1:1

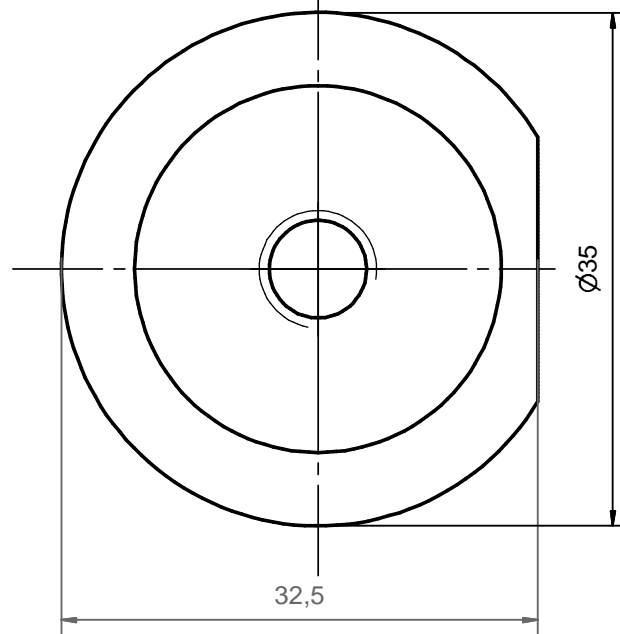
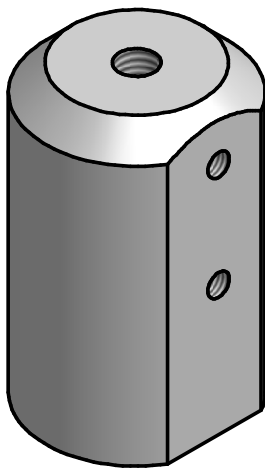

Rz25

				Zul.Abw.	Oberfläche	Maßstab:	Pos. Nr.: 2
				DIN ISO 2768- m	DIN ISO 1302	Werkstoff: 10SMn28	
						Rohteil: Rd 35x57	
				Datum	Name	<h1>Kessel</h1>	
				Bearb. 22.03.2007	B.Kumpf		
				Gep.			
				Norm			
				Gewerbeschule Lörrach		Lokomotive	4
							A4
Status	Änderungen	Datum	Name	B.Kumpf GWS-Lörrach 07621/429-311 B.Kumpf@gws-loerrach.de			

Pos.6

M 5:1

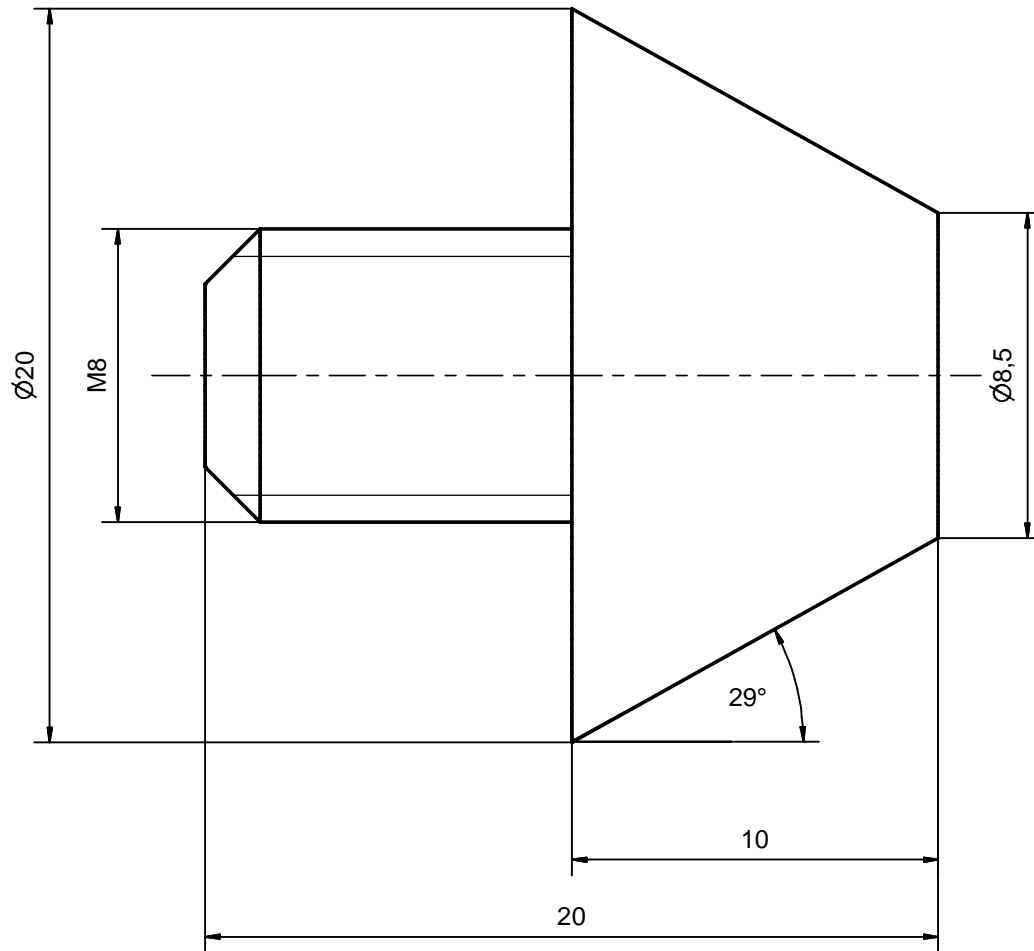

M 2:1

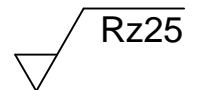
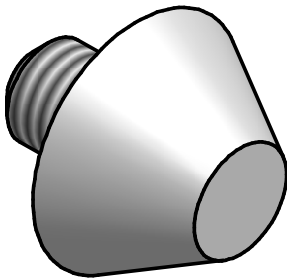

				Zul.Abw.		Oberfläche		Maßstab:		Pos. Nr.: 6	
				DIN ISO 2768- m		DIN ISO 1302		Werkstoff: CuZn42			
								Rohteil: Rd 20 v. d. St.			
				Datum		Name		<h1>Kesselspitze</h1>			
				Bearb. 23.03.2007		B.Kumpf					
				Gepr.							
				Norm							
				Gewerbeschule Lörrach				Lokomotive			
								5			
								A4			
Status	Änderungen	Datum	Name	B.Kumpf GWS-Lörrach 07621/429 -311 B.Kumpf@gws-loerrach.de							

Pos. 4 M 1:1

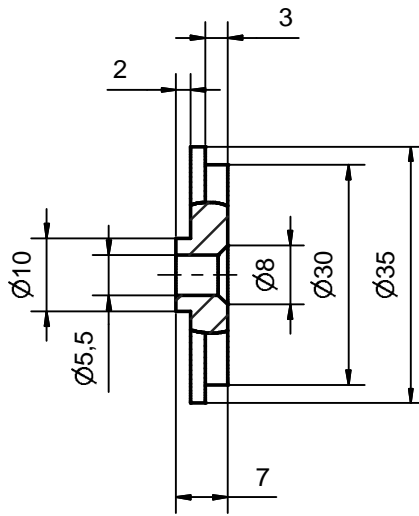
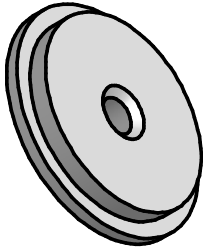

Pos.5 M 2:1

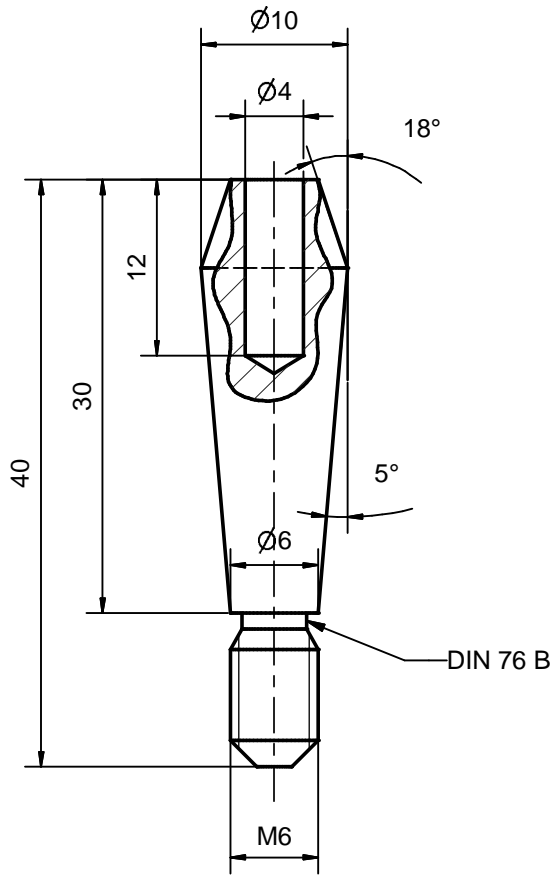
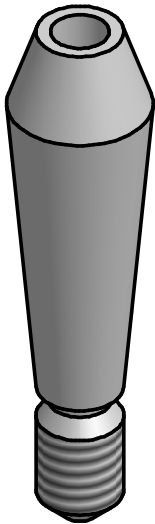

Rz25

				Zul.Abw.	Oberfläche	Maßstab:	Pos. Nr.: 4 + 5
				DIN ISO 2768- m	DIN ISO 1302	Werkstoff: 10SMn28	
						Rohteil: Rd 35 v d. st. Rd 10 x42	
				Datum	Name	Zugrad+ Kamin	
				Bearb. 22.03.2007	B.Kumpf		
				Gepr.			
				Norm			
				Gewerbeschule Lörrach		Lokomotive	6
							A4
Status	Änderungen	Datum	Name	B.Kumpf GWS-Lörrach 07621/429 -311 B.Kumpf@gws-loerrach.de			